

**Modular Cooking Range Line  
 thermaline 80 - 2 Zone Freestanding  
 Electric Solid Top with Ecotop, 2 Sides,  
 H=800**

ITEM # \_\_\_\_\_

MODEL # \_\_\_\_\_

NAME # \_\_\_\_\_

SIS # \_\_\_\_\_

AIA # \_\_\_\_\_



**588355 (MALBFCEDAO)** Electric solid top, 2 zones, ecotop coating, two-side operated

### Short Form Specification

**Item No.** \_\_\_\_\_

Unit constructed according to DIN 18860\_2 with 20 mm drop nose top and 70 mm recessed plinth. Internal frame for heavy duty sturdiness in 2 mm and 3 mm in 1.4301 (AISI 304). 2 mm top in 1.4301 (AISI 304). Flat surface construction, easily cleanable. THERMODUL connection system enables seamless worktop when units are connected and avoids soil penetrating. ECOTOP model with a 14 mm thick mild steel cooking surface with heat retaining coating. 2 independently controlled heating zones with 2 electronic sensors per zone for temperature surface control and 8 power levels. Rapid plate heat up, continuously ready to use. Overheat protection switches off the supply in case of overheating. Standby function saves energy and quickly recovers maximum power. Metal knobs with embedded hygienic silicon "soft" grip enable easier handling and cleaning. IPX5 water resistance certification. Configuration: Freestanding, two-side operated.

### Main Features

- 2 heating zones independently controlled.
- Rapid heat up of the plate and continuously ready for use.
- Overheat protection: a temperature sensor switches off the supply in case of overheating.
- Pans can easily be moved from one area to another without lifting.
- Wide rounded cleaning zone around the plates for easier cleaning.
- All major components may be easily accessed from the front.
- ECOTOP model has a 20 mm thick steel DIN 1.7335 nickel coated cooking surface.
- THERMODUL connection system creates a seamless work top when units are connected to each other thus avoiding soil penetrating vital components and facilitating the removal of units in case of replacement or service.
- Metal knobs with embedded hygienic "soft-touch" grip for easier handling and cleaning. The special design of the controls prevents infiltration of liquids or soil into vital components.
- Large visible digital display manufactured in tempered glass to resist heat and chemicals, showing temperatures or power settings. The display also shows on/off status of the appliance and on/off status of the heating elements.
- Cooking plate and base joint profile guarantee against soil infiltration.
- Two electronic sensors per zone to control surface temperature and to protect cooking plate from overheating.
- 8 power levels.

### Construction

- 2 mm top in 1.4301 (AISI 304).
- Unit constructed according to DIN 18860\_2 with 20 mm drop nose top and 70 mm recessed plinth.
- Flat surface construction with minimal hidden areas to easily clean all surfaces
- Unit constructed according to DIN 18860\_2 with 20 mm drop nose top.
- IPX5 water resistance certification.
- Internal frame for heavy duty sturdiness in stainless steel.

### Sustainability

- Standby function for energy saving and fast recovery of maximum power.



**APPROVAL:** \_\_\_\_\_

### Optional Accessories

- Connecting rail kit, 800mm PNC 912500
- Stainless steel side panel (12mm), 800x800mm, freestanding PNC 912508
- Portioning shelf, 500mm width PNC 912523
- Portioning shelf, 500mm width PNC 912553
- Folding shelf, 300x800mm PNC 912577
- Folding shelf, 400x800mm PNC 912578
- Fixed side shelf, 200x800mm PNC 912583
- Fixed side shelf, 300x800mm PNC 912584
- Fixed side shelf, 400x800mm PNC 912585
- Stainless steel front kicking strip, 500mm width PNC 912595
- Stainless steel side kicking strips left and right, freestanding, 800mm width PNC 912619
- Stainless steel plinth, freestanding, 500mm width PNC 912822
- Connecting rail kit, right PNC 912971
- Connecting rail kit, left PNC 912972
- Endrail kit, flush-fitting, left PNC 913109
- Endrail kit, flush-fitting, right PNC 913110
- Endrail kit (12mm) for thermaline 80 units, left PNC 913200
- Endrail kit (12mm) for thermaline 80 units, right PNC 913201
- INSERT.PROFILE,D800,TL-OTHER BRANDS PNC 913230
- - NOT TRANSLATED - PNC 913233
- - NOT TRANSLATED - PNC 913244
- - NOT TRANSLATED - PNC 913257
- - NOT TRANSLATED - PNC 913279
- FILTER W=500MM PNC 913664
- STAINLESS STEEL DIVIDING PANEL 800X800MM LEFT/RIGHT PNC 913669
- ELECTRIC MAINSWITCH 25A 4mm<sup>2</sup> NM FOR MODULAR H800 ELECTRIC UNITS (FACTORY FITTED) PNC 913676
- - NOT TRANSLATED - PNC 913685

Front

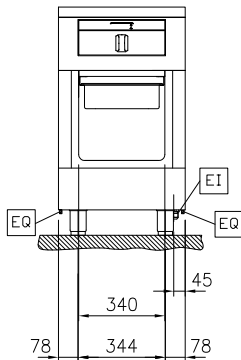

Side

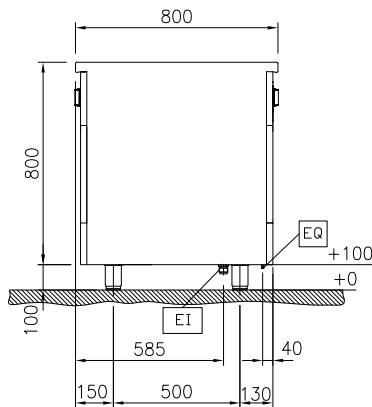

EI = Electrical inlet (power)  
 EQ = Equipotential screw

Top

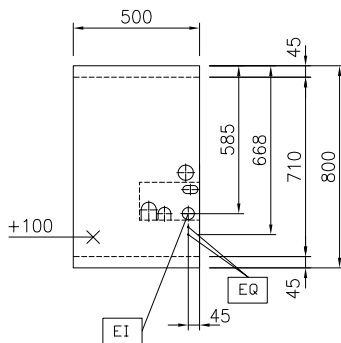
**Electric**

Supply voltage: 400 V/3N ph/50/60 Hz  
 Electrical power max.: 6 kW

**Key Information:**

Working Temperature MIN: 100 °C  
 Working Temperature MAX: 450 °C  
 External dimensions, Width: 500 mm  
 External dimensions, Depth: 800 mm  
 External dimensions, Height: 800 mm  
 Storage Cavity Dimensions (width): 340 mm  
 Storage Cavity Dimensions (height): 330 mm  
 Storage Cavity Dimensions (depth): 740 mm  
 Net weight: 93 kg  
 Configuration: On Base;Two-Side Operated  
 Front Plates Power: 3 - 0 kW  
 Back Plates Power: 3 - kW  
 Solid top usable surface (width): 360 mm  
 Solid top usable surface (depth): 630 mm

**Sustainability**

Current consumption: 13 Amps